

## I B. Tech I Semester Supplementary Examinations, July/August - 2021

## ENGINEERING MECHANICS

(Com. to CE, Auto E, Min E)

Time: 3 hours

Max. Marks: 75

Answer any five Questions one Question from Each Unit

All Questions Carry Equal Marks

1. a) What differences exist between kinetics and kinematics? State and explain Newton's law of gravitation and Newton's three laws of motion? (8M)
- b) A body, resting on a rough horizontal plane, required a pull of 180 N inclined at  $30^\circ$  to the plane just to move it. It was found that a push of 220 N inclined at  $30^\circ$  to the plane just moved the body. Determine the weight of the body and the coefficient of friction. (7M)
- Or
2. a) Two forces acts at an angle of  $120^\circ$ . The bigger force is of 40 N and the resultant is perpendicular to the smaller one. Find the smaller force (8M)
- b) Explain the method of resolution for determining the resultant force of a Force system. (7M)
3. a) What is free body diagram? Explain with a suitable example. (5M)
- b) Determine the reactions at the points of supports A, B and C for two identical rollers of each weight 250 N are supported by a vertical wall and an inclined plane as shown in figure. (10M)

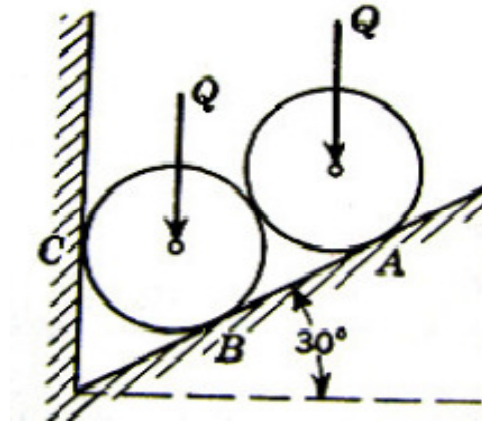

Figure

Or

4. a) Figure shows a support assembly. it is kept in place by blots at points A, B and C. (10M) when a vertical force F is exerted at point P, the forces exerted on support are along members PA, PB and PC. If force on PA be 29.2 N. Find the magnitude of force F.



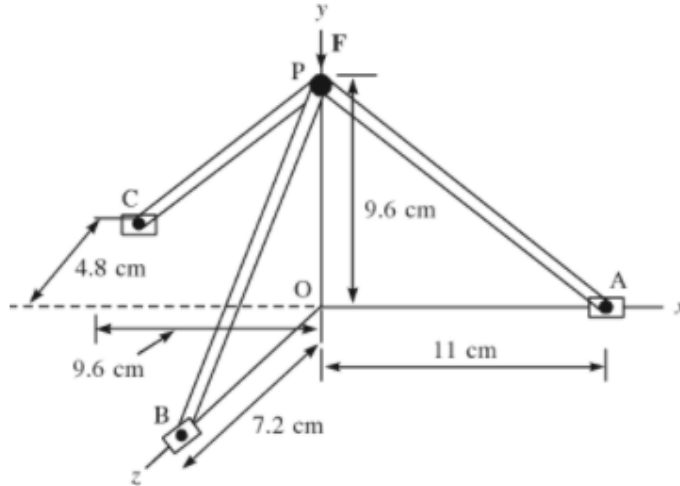

Figure

- b) State and prove Lami's theorem. (5M)
- 5. a) State and explain Pappus-Guldinus theorems for surface of revolution and volume of revolution. (7M)
- b) Determine the centroid of the area shown in figure with respect to the axis shown. (8M)

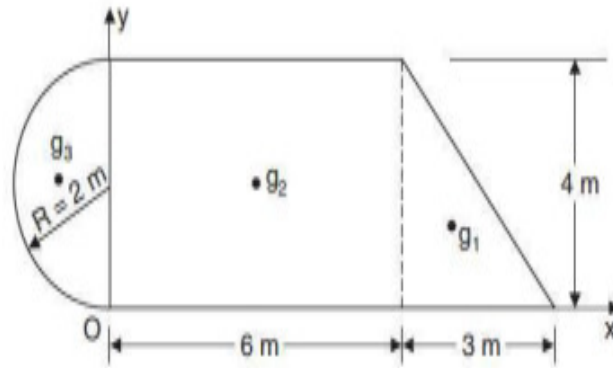
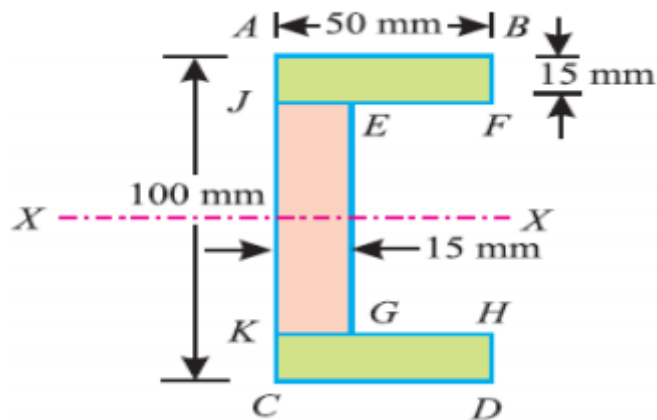

Figure  
Or

- 6. a) Find the centre of gravity of a channel section 100 mm × 50 mm × 15 mm as shown in figure. (8M)



Figure



- b) A shown in figure two blocks each weighting 20 kN and resting on a horizontal surface, are to be pushed apart by a  $30^\circ$  wedge. The angle of friction is  $15^\circ$  for all contact surfaces. What value of P is required to start movement of the blocks? (7M)

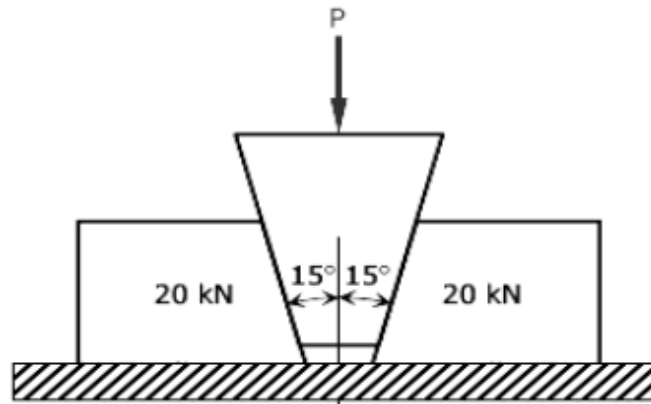

Figure

7. a) Find the moment of inertia for the unequal angle section  $100 \times 100 \times 12.5$  mm shown in Fig. 6 (8M)

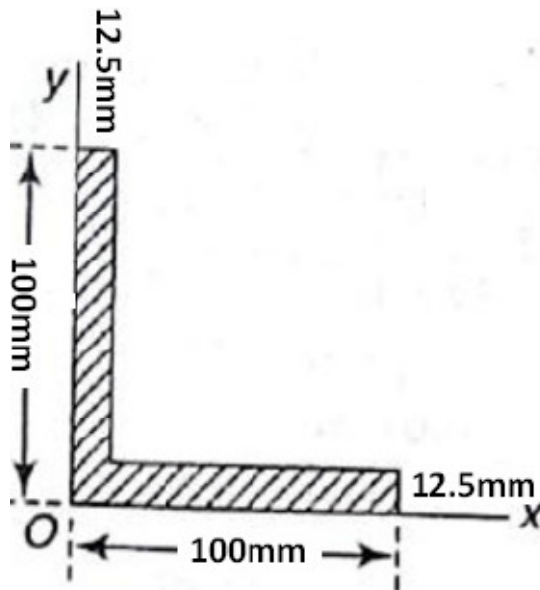

Figure

- b) Prove the parallel axis theorem in the determination of moment of inertia of areas with the help of a neat sketch. (7M)
- Or
8. a) Two uniform rods, each of mass 40 kg and length 3m are welded together to form a T shape assembly, which is pin suspended at O as shown in fig.7 Determine the mass moment of inertia of the assembly about pin axis at O. (7M)



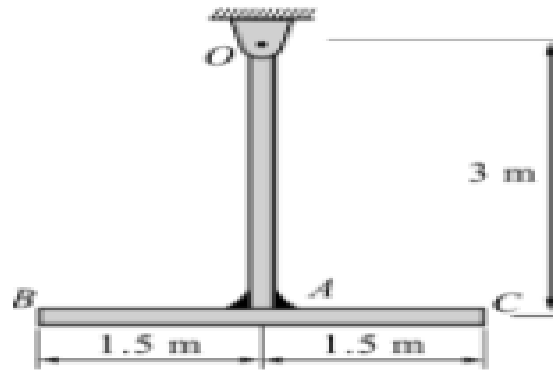

Figure

- b) Find the product of inertia of the area of the quadrant of a circular area with respect to x and y axis. (8M)
9. a) An elevator gross weight 15 kN is moving in the upward direction, such that the displacement is given by  $x = t^3 - 4t^2 + 6t + 7$  m. Determine the tension in the cable supporting the elevator at  $t = 2$  seconds. (8M)
- b) Define instantaneous centre of rotation (ICR). Write kinematic equations of linear motion with constant acceleration. (7M)
- Or
- 10 a) A gun of mass 30 tonnes fires a 456Kg projectile with a velocity of 305 m/s. With what initial velocity will the gun recoil? If the recoil is overcome by an average force of 600KN, how far will the gun travel? How long will it take? (8M)
- b) Derive the expression for work energy equation of a body rotating about a fixed axis. (7M)

